

Sullivan Palatek®

DG Series Compressors



Shown with optional
tank mount



INDUSTRIAL AIR COMPRESSOR - 25, 30, 40, 50 HP Direct Gear Drive

COMPRESSOR UNIT:

- » Fluid flooded rotary screw, continuous duty, industrial air compressor.
- » Direct coupled to motor for positive alignment.
- » **5 Year Platinum Warranty/10 Year Platinum Plus Warranty Available**

ELECTRIC MOTOR:

- » Nema T-frame, C-face, double shaft, open drip proof squirrel cage induction type.
- » 200/230/460/575/3/60 - 380/3/50
- » **5 Year Platinum Warranty Available**

MOTOR STARTER:

- » Full voltage magnetic starter with 115 controls, Nema 1 enclosure, circuit breaker, transformer and three-phase overload protector.

COUPLING & DRIVE:

- » Compressor is flange mounted to motor C-face for positive alignment and gear driven with low maintenance coupling.
- » **5 Year Platinum Warranty Available**

AIR INTAKE FILTER:

- » Corrosion resistant housing
- » Oversize multi-stage dry type with replaceable element.

MOUNTING:

- » Base mounted, no special foundation required
- » Optional tank and platform mounting available.

COOLING SYSTEM:

- » Air-cooled with air/oil aftercooler and factory filled with Palasyn 45 synthetic lubricoolant.
- » **5 Year Platinum Warranty Available.**

CONTROLS:

- » Auto dual control, full modulation, timed stop or constant run standard.
- » Analog controlled for smooth operation and lowest possible no load power.
- » Optional microprocessor.

INSTRUMENTATION:

- » Line pressure gauge, fluid reservoir sightglass, hour meter, discharge temperature gauge, fluid filter and separator element differential gauges.

PROTECTIVE DEVICES:

- » Class 20 overload relay, high temperature and overpressure shutdown.

LUBRICATION:

- » Factory filled with 4000 hour Palasyn 45
- » Equipped with microfiber full flow, spin on oil filter.

COMPRESSOR TECHNICAL DATA

MODEL	25 DG	30 DG	40 DG	50 DG
COMPRESSOR DATA				
CFM	105	125	160	225
Drive Motor	25	30	40	50
Motor Speed (RPM)	1750	1750	1750	1750
Air Discharge (Inches)	1"	1"	1 1/4"	2"
Length (Inches) (A)	64	64	65	65
Width (Inches) (B)	33	33	35	34
Height (Inches) (C)	37	37	37	43
Weight (LBS)	950	990	1220	1320
COOLING DATA, AIR COOLED				
Oil sump, fluid capacity	6 Gal.	6 Gal.	6 Gal.	6 Gal.
Note: Rated capacity in ACFM is based on standard conditions @125 psig. Capacity will vary with ambient conditions; i.e. temperature and barometric pressure, and compressor output pressure.				

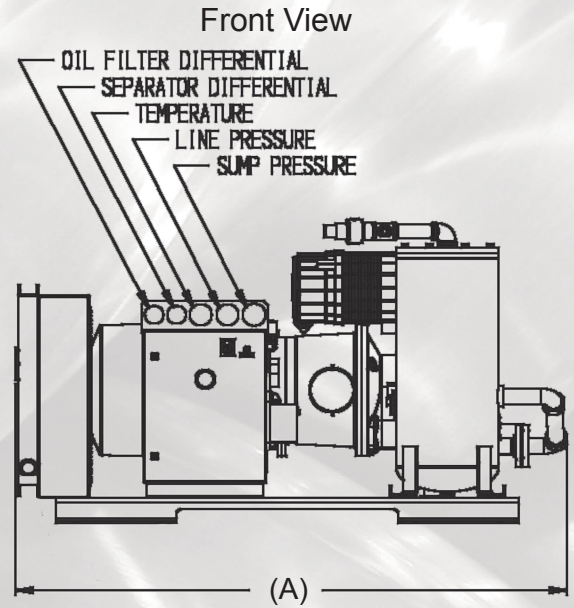

Description, Specifications and Pictures represented in this literature may vary from actual equipment purchased.



Compressor Options:

- Air filter pop-up indicator
- Auto restart
- Base load transfer 2 or 3 machines
- CDD - Intergrated Desiccant Dryer System
- CRP - Condensate Management Package
- Enclosure
- HATD Shutdown switch
- Microprocessor control
- Motor option TEFC
- Percent capacity gauge
- Platform mounted (25-30-40 HP)
- Receiver 240 or 400 gallon vertical
- Separator trap
- Starter options: Nema-4, Wye - Delta, Solid State, or VFD
- Tank mount 120, 200, 240 gallon
- Water cooled

Call for complete information regarding all features and options.

Side View

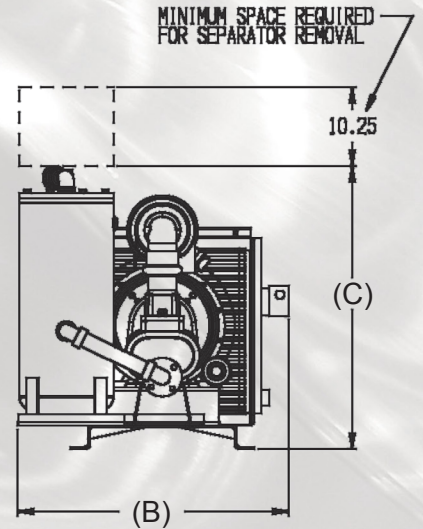

Top View

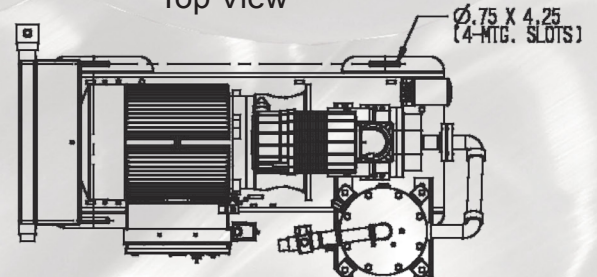

Distributed By:

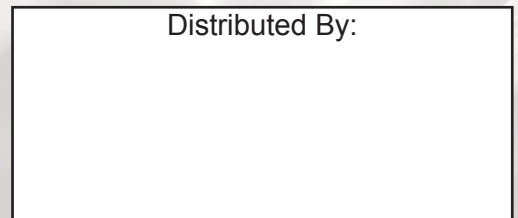

**Sullivan
Palatek**

1201 W. US Highway 20
Michigan City, IN 46360
Tel: 219-874-2497
Tel: 800-438-6203
www.sullivanpalatek.com
Email: info@palatek.com